

Operation Manual

Model RGM-700

General Description:

Refractive index is one of most important optical parameters. Gloss of gem can be estimated by the parameter.

The kinds of gem can be precisely determined in accordance with the measured value of refractive index because every kind of gem has its inherent refractive index. Besides, index of double of refraction can be also measured. Through the parameter you can judge whether a gem is uniaxial or biaxial photopositive or photonegative.

The gemological refractometer is characterized by small volume and less weight. It is easy to carry. It is popular instrument used on jewelry market. The model RGM-700 was equipped with a built-in light source. It is more convenient to test!

Specification:

Range: 1.30-1.81RI

Minimum Division: 0.01

Accuracy: ± 0.02

Size: 115 x 35 x 63mm

Power supply: 4.5V(three pieces button battery)

Parts Diagram:

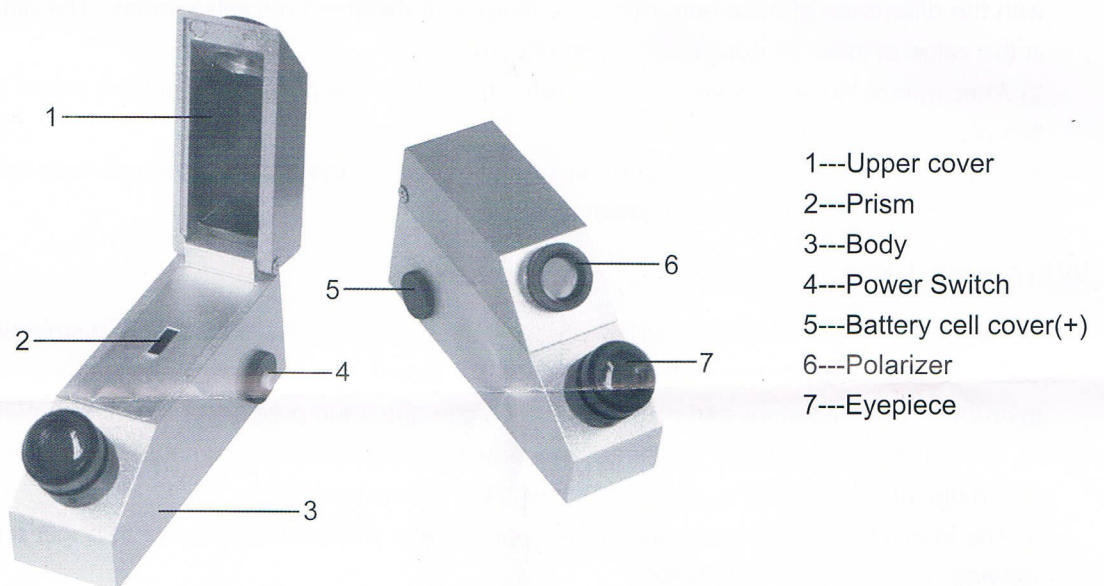

Remarks: The battery cover is the anode

Method of Operation:

- 1) Lay the instrument on the worktable. Open the upper cover. Drop a few drops special refractive oil onto the surface of prism by a thin glass Bar.
- 2) Make the ground surface of gem to be measured close up to the prism, Press it lightly, make the refractive oil distributed evenly between the two surface. Then close the upper cover.
- 3) Align the entrance filter of refractometer and light source, make luminance of viewing field even.
- 4) Move eyepiece up and down. Adjust diopter approximately. Now you can see a light/dark boundary in viewing field. The graduation on which the boundary located is the refractive index of gem as shown in right figure.
- 5) The index of double refraction of gem can be measured precisely because the filter of the refractometer can eliminate the phenomenon of dispersion.

Measuring Methods:

- 1) Remove the polarizer. Turn it onto eyepiece. Then turn the polarizer lightly. You can only read the refractive index in one direction at a time because the polarizer only allows the light vibrated in one direction to pass through. Then turn the polarizer through 90° , you can measure the refractive index value of the light vibrated at right angles to that mentioned above. Turn the gem in the same direction through small degrees then turn the polarizer lightly according to above method, you can read the two refractive index values of the light vibrated at right angles to each other. Operate continuously until the gem is at 180° position to its initial position. From a number of groups of measured refractive index values you can find a group with the difference of maximum refractive index and minimum refractive index. The difference is the value of index of double refraction of gem.
- 2) After measurement, clean away the refractive oil on the prism then put the prism into the box of instrument for protection.
- 3) The precision of the instrument can be calibrated by the block. If there is any error, the measured value should be compensated.

Warnings- Maintenance:

- 1) The instrument is composed of precise components. You should not dismantle it by yourself. After usage, the instrument should be stored in dry place, in order to protect the instrument from moisture and mildewing which can affect the precision of the instrument.
- 2) The refractive oil should be stored and sealed. While using it, you should use a thin glass bar to dip into it, don't bring oil into touch with the hands or eyes.
- 3) The intensity of light source should be approximate. It should be suitable to bright and even viewing field and clear observation.
- 4) This is an optical instrument. It requires careful handling and storage. Failure to do so can result in damage to the optical components and its basic structure. With care, this unit will provide years of reliable service